

This catalog covers:
FH541V-□S06

GRID NO. This grid covers:
A-01 TITLE

PARTS CATALOG

4-STROKE ENGINE

FH541V

PRODUCT CODE	NOTE
FH541V-AS06	FLOOR BURNISHER

PARTS CATALOG INTRODUCTION

This parts catalog lists parts and sub-assemblies provided as service parts. When it becomes necessary to replace parts, always use KAWASAKI GENUINE PARTS which have passed strict inspection which guarantees quality and performance.

1. HOW TO ORDER PARTS

- When ordering the parts, be sure to use the parts catalog corresponding to the product code. Check the product revision codes on the product and the catalog.
 Product Code (example) : FA130D-**A**A00
 Product Revision Code
- Specify the part code (all digits) exactly as listed in this catalog on your parts order.
- The parts not shown in the illustrations of this catalog are not sold separately; only the complete units or next higher assemblies illustrated are supplied as the service parts.

2. EXPLANATION OF PARTS CATALOG FORMAT

Ref. No.	Part No.	Description	Quantity	
			A	B
11004	11004-7001	GASKET-HEAD	2	2
11008	11008-7001	HEAD-COMP-CYLINDER#1	1	1
11008A	11008-7002	HEAD-COMP-CYLINDER#2	1	1
11022	11022-7001	CASE-ROCKER	2	2
11060	11060-7001	GASKET,ROCKER CASE	2	2
11060A	11060-7008	GASKET,CRANKCASE COVER	1	1
11060B	11060-7015	GASKET,BREATHER	1	1
13271	13271-7016	PLATE	1	1
13271A	13271-7016	PLATE	1	1
14690	14690-7001	COVER,BREATHER	1	1
49015	49015-6215	COVER,CRANKCASE	1	1
49109	49109-7002	ELEMENT-BREATHER	1	1
49120	49120-6119	CRANKCASE-COMP	1	1
92033	92033-7003	RING-SNAP	2	2
92043	92043-7001	PIN	6	6
92049	92049-7001	SEAL-OIL	4	4
92049A	92049-7002	SEAL-OIL	1	1
92049B	92049-7004	SEAL-OIL	1	1
92049C	92049-7005	SEAL-OIL	1	1
130	130B0612	BOLT-FLANGED	4	4
130A	130B0640	BOLT-FLANGED	4	4
130B	130T0650	BOLT-FLANGED	17	17
130C	130T0875	BOLT-FLANGED	2	2
172	172G0818	BOLT-STUD	4	4

1) Product Code

This code describes the product code covered by this catalog. The product revision code, which is a part of the product code, is omitted.

2) Part Group Title

This title is the representative name for the group of parts illustrated on the page.

3) Reference Number

The reference numbers are shown on the illustration and the list as the link between them.

4) Part Number

This is the key of your parts ordering. Three kinds of part number are used in this catalog.

- Structure 1
 □□□□□□-□□□□□□-□□
 □□□□□□-□□□□□□
 Part Revision Code
- Structure 2
 □□□□□□-□□□□□□-□□
 Color Code for Painted Part
- Standard Hardware Number
 (for bolts, nuts, washer, or the like)
 □□□□□□□□
 Size Code
 Material and Surface Treatment Code
 Item Code

5) Description and Additional Information

The part name, the location, the size, and the serial number as additional information, etc. are described here. Use them to find out and check the part required.

When a part number is changed without change of the product revision code and the changed parts are not interchangeable, the serial number of the product is noted as follows;

- (FA130 - 100001) : Affected units are from beginning of the product of the product code up to and including this serial number.
- (FA130 - 100002 -) : Affected units are from this serial number and above.
- (FA130 - 100002 - FA130 - 110001) : Affected units are in this serial number range.

6) Quantity

The figure shows quantity of the part required at the indicated position on the illustration and for the specified product revision code.

The asterisk (*) on this column means the part can be used as the substitute on the product and is supplied until the stock is exhausted.

Note:Some small parts will be supplied by units.

Example: If six (6) bolts are ordered and the minimum quantity per unit is five (5), two (2), units of the bolt will be delivered.

7) Product Revision Code

This Code indicates an important change which affects the service parts interchangeability.

3. ABBREVIATIONS

#.....Number	FR.....Front	RH.....Right Hand
&.....And	G.....Gram	RPM.....Revolutions Per Minute
(+).....Plus	HEX.....Hexagonal	RR.....Rear
(-).....Minus	ID=.....Inside Diameter	STD.....Standard
2ND.....Second	IN.....Inch	T.....Teeth
3RD.....Third	L=.....Length	T=.....Thickness
4TH.....Fourth	LH.....Left Hand	U/S.....Under Size
A.....Ampere	LWR.....Lower	UPP.....Upper
AR.....As Required	MM.....Millimeter	V.....Volt
ASSY.....Assembly	O/S.....Over Size	W.....Watt
CNT.....Center	OD=.....Outside Diameter	
COMP.....Complete	REF.....Reference	

This catalog covers:

FH541V- □ S06

GRID NO.

B-01

This grid covers:

PICTORIAL INDEX

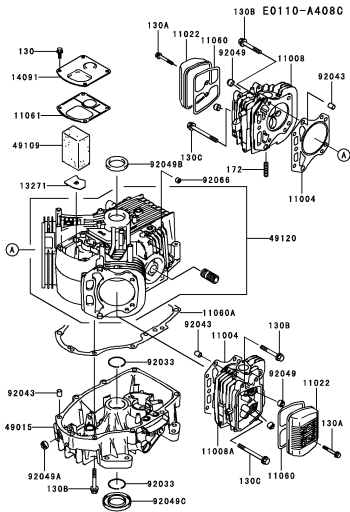

B-03 CYLINDER/CRANKCASE

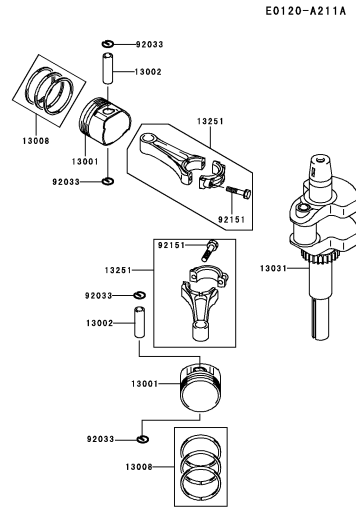

B-04 PISTON/CRANKSHAFT

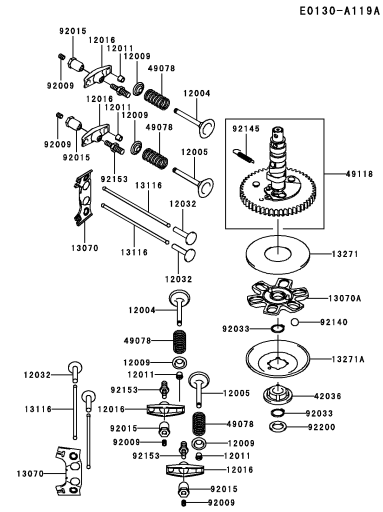

B-05 VALVE/CAMSHAFT

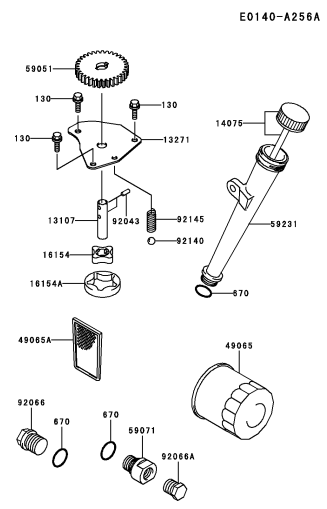

B-06 LUBRICATION-EQUIPMENT

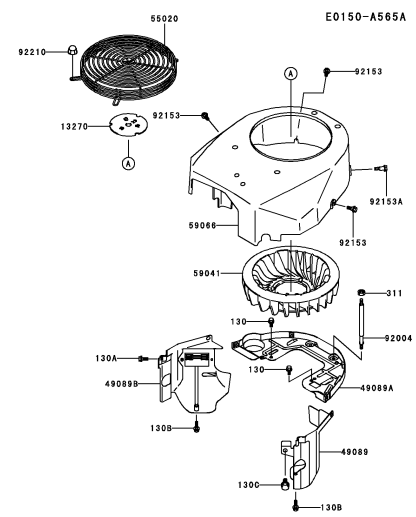

B-07 COOLING-EQUIPMENT

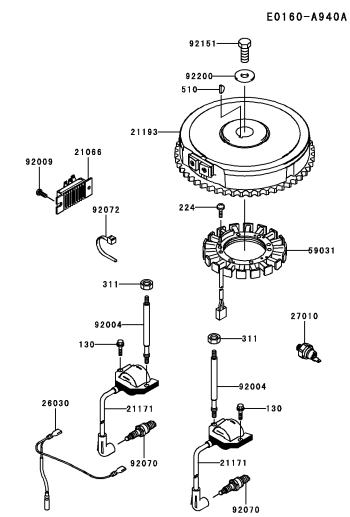

B-08 ELECTRIC-EQUIPMENT

This catalog covers:

FH541V- □ S06

GRID NO.

B-02

This grid covers:

PICTORIAL INDEX

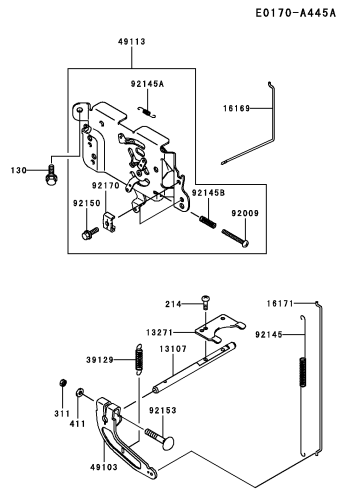

B-09

CONTROL-EQUIPMENT

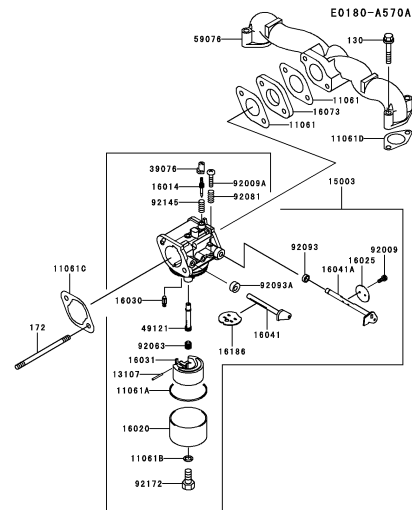

B-10

CARBURETOR

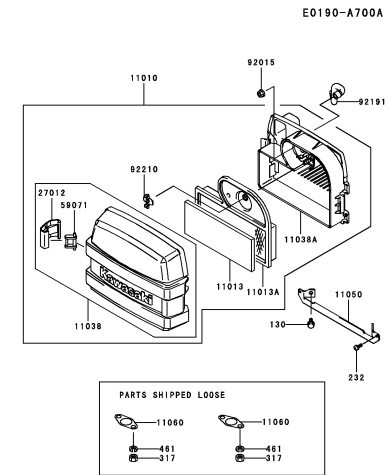

B-11

AIR-FILTER/MUFFLER

This catalog covers:

FH541V- □ **S06**

GRID NO.

C-01

This grid covers:

PICTORIAL INDEX

E0200-A274A

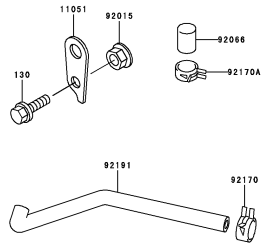

C-03

FUEL-TANK/FUEL-VALVE

E0210-A205A

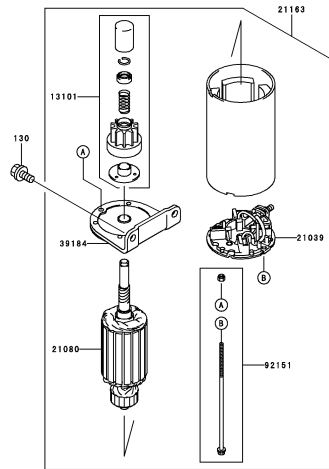

C-04

STARTER

This catalog covers:

FH541V- □ S06

GRID NO.

D-01

This grid covers:

PICTORIAL INDEX

F0290-B053A

56033



56070



56080



D-03

LABEL

This catalog covers:

FH541V- □ S06

GRID NO.

B-03

This grid covers:

CYLINDER/CRANKCASE

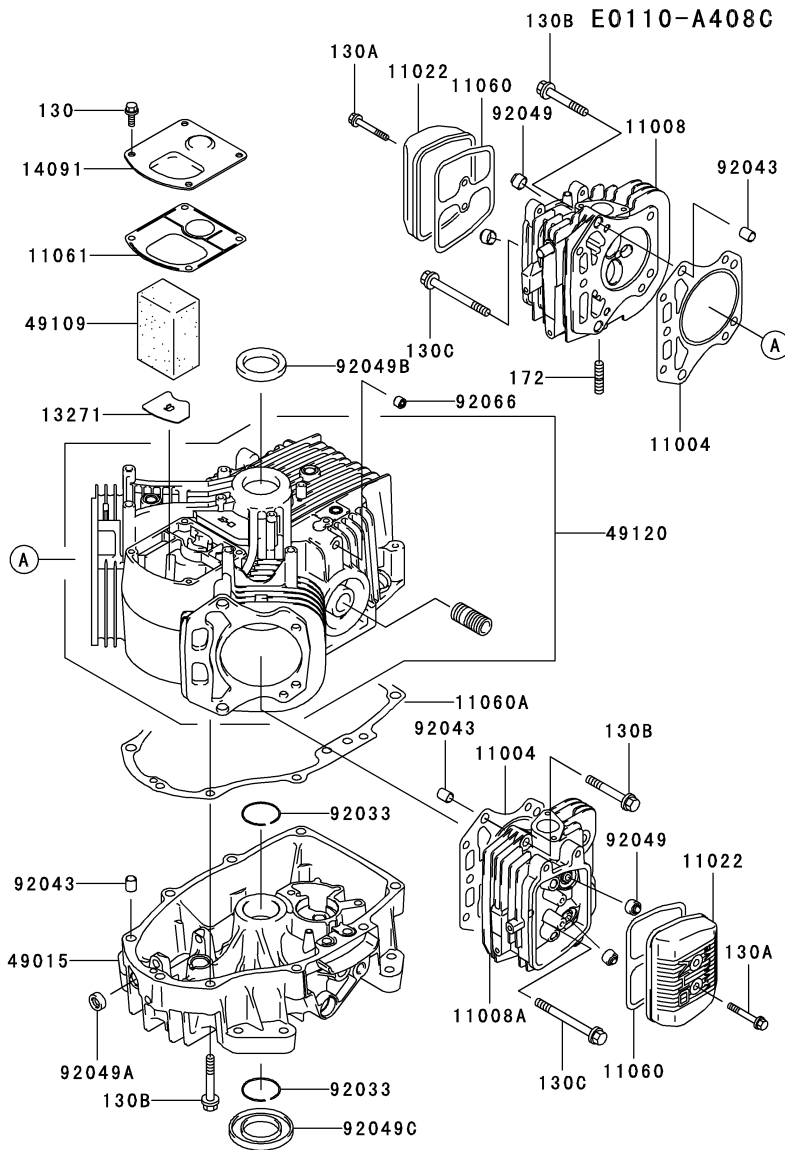

Ref. No.	Part No.	Description	Quantity
11004	11004-7010	GASKET-HEAD	2
11008	11008-6042	HEAD-COMP-CYLINDER	1
11008A	11008-7009	HEAD-COMP-CYLINDER	1
11022	11022-7003	CASE-ROCKER	2
11060	11060-7001	GASKET,ROCKER CASE	2
11060A	11060-7008	GASKET,CRANKCASE COVER	1
11061	11061-7001	GASKET,BREATHER	1
13271	13271-7016	PLATE	1
14091	14091-7006	COVER	1
49015	49015-6253	COVER-CRANKCASE	1
49109	49109-7002	ELEMENT-BREATHER	1
49120	49120-7023	CRANKCASE-COMP	1
92033	92033-7003	RING-SNAP	2
92043	92043-7001	PIN	6
92049	92049-7001	SEAL-OIL,RVC2 6X11X10.2	4
92049A	92049-7005	SEAL-OIL,SO 8X14X5 HS	1
92049B	92049-7010	SEAL-OIL,SD 35X48X8 R HS	1
92049C	92049-7011	SEAL-OIL,SD 35X62X8 L HS	1
92066	92066-7002	PLUG	1
130	130B0612	BOLT-FLANGED	4
130A	130B0640	BOLT-FLANGED	4
130B	130T0850	BOLT-FLANGED	17
130C	130T0875	BOLT-FLANGED	2
172	172G0818	BOLT-STUD	4

This catalog covers:

FH541V- □ S06

GRID NO.

B-04

This grid covers:

PISTON/CRANKSHAFT

E0120-A211A

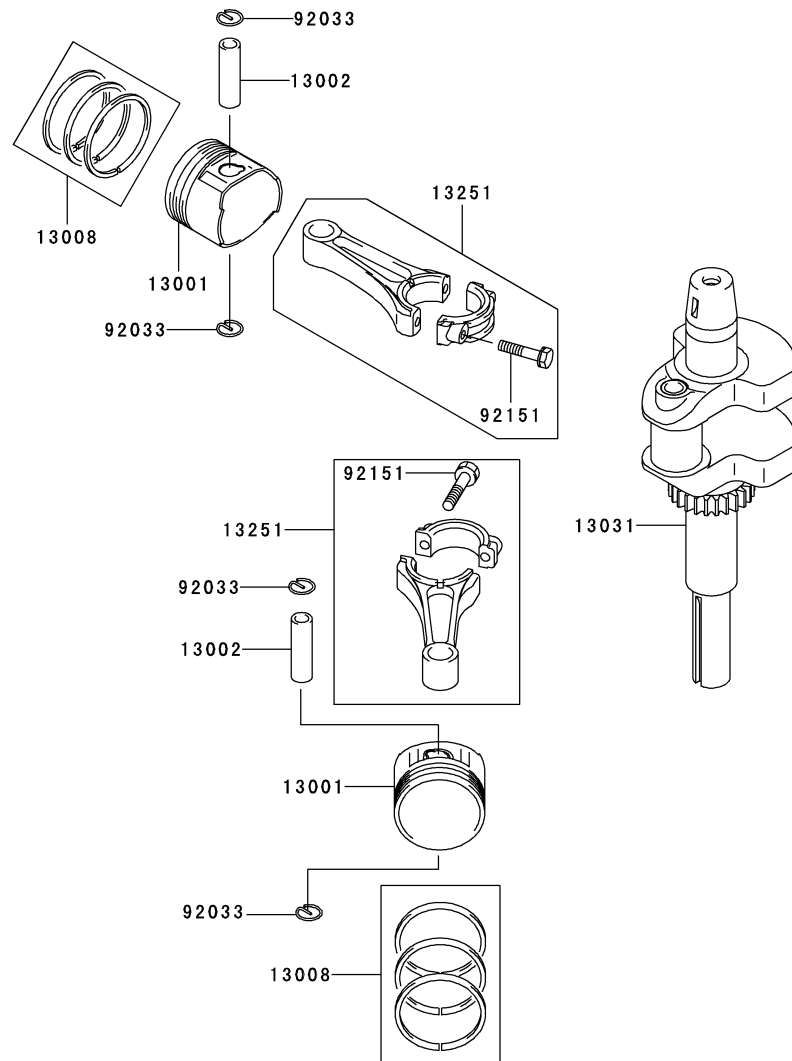

Ref. No.	Part No.	Description	Quantity
13001	13001-7010	PISTON-ENGINE	2
13002	13002-7001	PIN-PISTON	2
13008	13008-6060	RING-SET-PISTON	2
13031	13031-7036	CRANKSHAFT-COMP	1
13251	13251-7010	ROD-ASSY-CONNECTING	2
92033	92033-7005	RING-SNAP	4
92151	92151-7017	BOLT,6X35	4

This catalog covers:

FH541V- □ S06

GRID NO.

B-05

This grid covers:

VALVE/CAMSHAFT

E0130-A119A

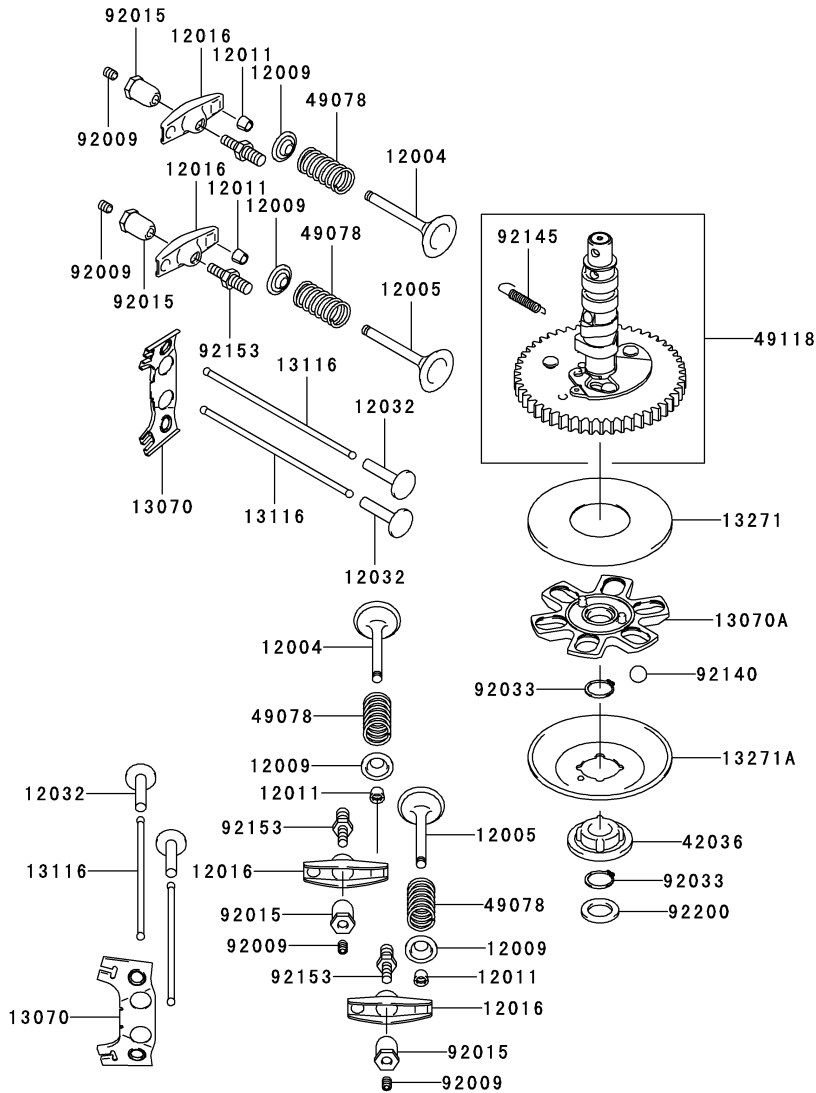

Ref. No.	Part No.	Description	Quantity
12004	12004-7003	VALVE-INTAKE	2
12005	12005-7003	VALVE-EXHAUST	2
12009	12009-7001	RETAINER-VALVE SPRING	4
12011	12011-2056	COLLET	8
12016	12016-7001	ARM-ROCKER	4
12032	12032-7001	TAPPET	4
13070	13070-7001	GUIDE	2
13070A	13070-7004	GUIDE	1
13116	13116-2057	ROD-PUSH	4
13271	13271-7007	PLATE	1
13271A	13271-7021	PLATE,GOVERNOR	1
42036	42036-7009	SLEEVE	1
49078	49078-7001	SPRING-ENGINE VALVE	4
49118	49118-7004	CAMSHAFT-COMP	1
92009	92009-2341	SCREW	4
92015	92015-2253	NUT	4
92033	92033-7001	RING-SNAP	2
92140	92140-7002	BALL	6
92145	92145-7001	SPRING	1
92153	92153-7019	BOLT	4
92200	92200-7001	WASHER	1

This catalog covers:

FH541V- □ S06

GRID NO.

B-06

This grid covers:

LUBRICATION-EQUIPMENT

E0140-A256A

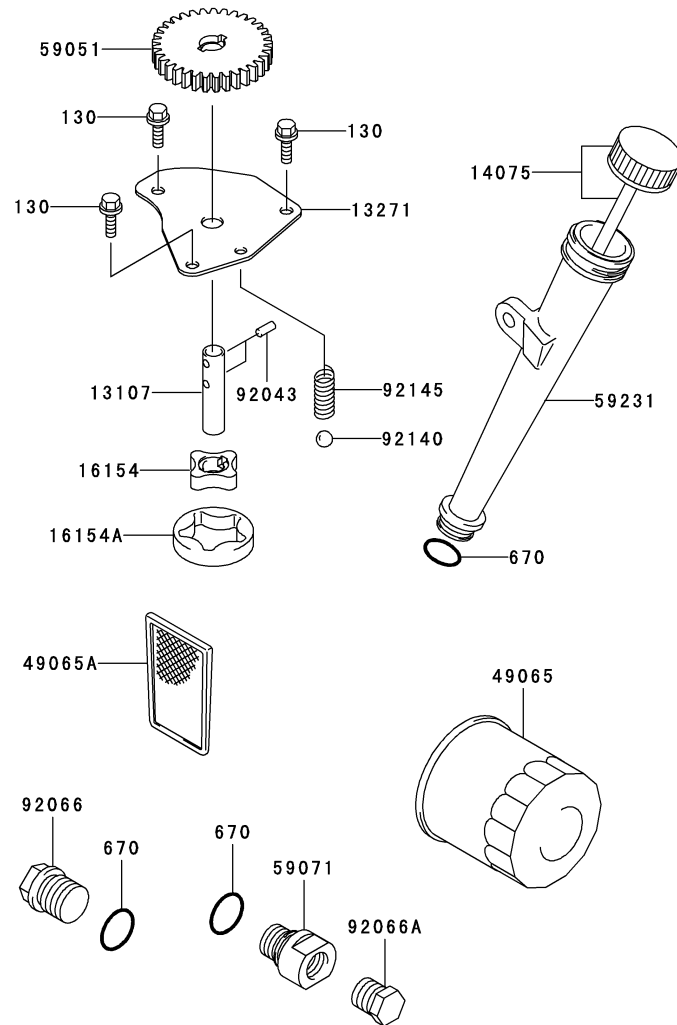

Ref. No.	Part No.	Description	Quantity
		A	
13107	13107-7009	SHAFT	1
13271	13271-7017	PLATE	1
14075	14075-7009	CAP-ASSY	1
16154	16154-2053	ROTOR-PUMP,IN	1
16154A	16154-2054	ROTOR-PUMP,OUT	1
49065	49065-2078	FILTER-OIL	1
49065A	49065-7004	FILTER-OIL	1
59051	59051-7011	GEAR-SPUR	1
59071	59071-7004	JOINT	1
59231	59231-7005	FILLER	1
92043	92043-7003	PIN	2
92066	92066-7003	PLUG	1
92066A	92066-7006	PLUG	1
92140	92140-7003	BALL	1
92145	92145-7002	SPRING	1
130	130B0612	BOLT-FLANGED	3
670	670D2016	O RING,16MM	3

This catalog covers:

FH541V- □ S06

GRID NO.

B-07

This grid covers:

COOLING-EQUIPMENT

E0150-A565A

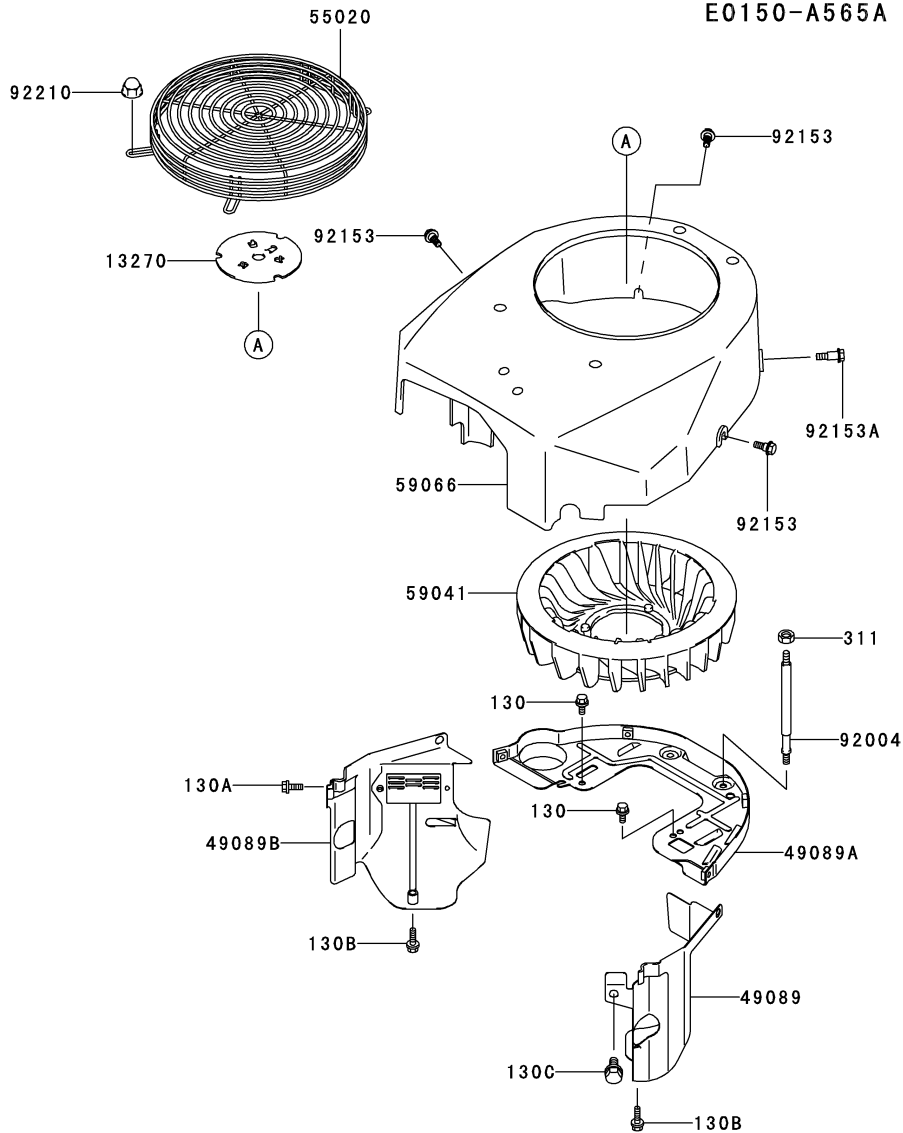

Ref. No.	Part No.	Description	Quantity
13270	13270-7007	PLATE	1
49089	49089-7002	SHROUD-ENGINE	1
49089A	49089-7032	SHROUD-ENGINE	1
49089B	49089-7034	SHROUD-ENGINE	1
55020	55020-7004	GUARD	1
59041	59041-7010	FAN	1
59066	59066-7002	HOUSING-FAN	1
92004	92004-7006	STUD	2
92153	92153-7007	BOLT	3
92153A	92153-7008	BOLT	1
92210	92210-0003	NUT	4
130	130B0612	BOLT-FLANGED	2
130A	130B0616	BOLT-FLANGED	1
130B	130B0625	BOLT-FLANGED	2
130C	130B0816	BOLT-FLANGED	1
311	311B0600	NUT-HEX	2

This catalog covers:

FH541V- □ S06

GRID NO.

B-08

This grid covers:

ELECTRIC-EQUIPMENT

E0160-A940A

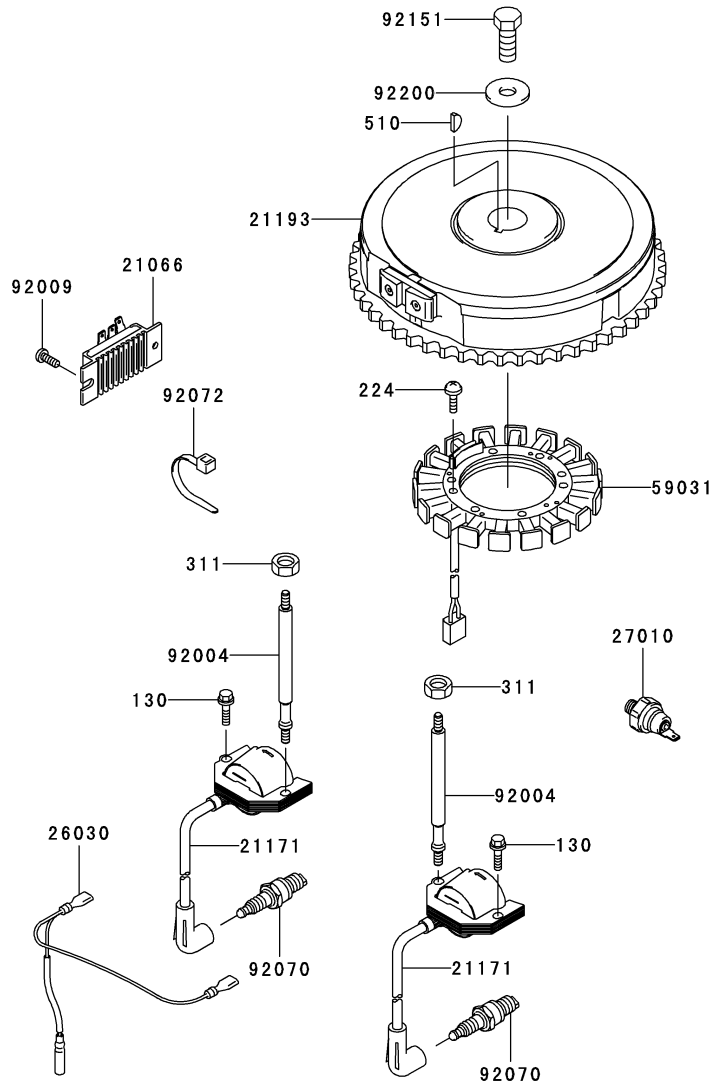

Ref. No.	Part No.	Description	Quantity
21066	21066-7011	REGULATOR-VOLTAGE	1
21171	21171-7013	COIL-ASSY-IGNITION	2
21193	21193-7007	FLYWHEEL-ASSY	1
26030	26030-7001	HARNESS	1
27010	27010-7002	SWITCH	1
59031	59031-7001	COIL-CHARGING	1
92004	92004-7009	STUD	2
92009	92009-2308	SCREW	1
92070	92070-7003	PLUG-SPARK,RCJ8Y,SOLID	2
92072	92072-7003	BAND	2
92151	92151-2097	BOLT,12X30	1
92200	92200-7002	WASHER	1
130	130B0620	BOLT-FLANGED	2
224	224B0520	SCREW-PAN-WP-CROS	4
311	311B0600	NUT-HEX	2
510	510A5100	KEY-WOODRUFF	1

This catalog covers:

FH541V- □ S06

GRID NO.

B-09

This grid covers:

CONTROL-EQUIPMENT

E0170-A445A

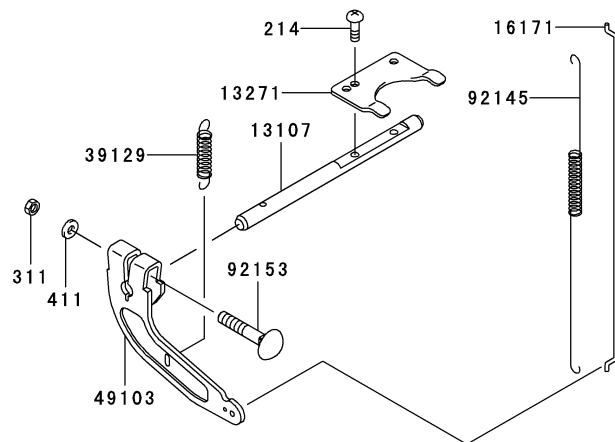
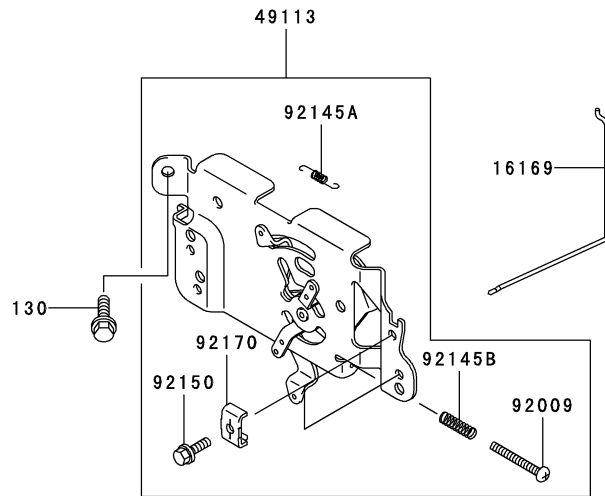

Ref. No.	Part No.	Description	Quantity
13107	13107-7010	SHAFT	1
13271	13271-7018	PLATE	1
16169	16169-7010	LINK-CHOKE	1
16171	16171-7001	LINK	1
39129	39129-7003	SPRING-GOVERNOR	1
49103	49103-7004	ARM-GOVERNOR	1
49113	49113-7011	PANEL-COMP-CONTROL	1
92009	92009-7007	SCREW,4X35	1
92145	92145-7003	SPRING	1
92145A	92145-7004	SPRING	1
92145B	92145-7005	SPRING	1
92150	92150-2182	BOLT,5X18	2
92153	92153-7005	BOLT,6X35	1
92170	92170-7001	CLAMP	2
130	130B0612	BOLT-FLANGED	2
214	214B0408	SCREW-PAN+	2
311	311B0600	NUT-HEX	1
411	411B0600	WASHER-PLAIN	1

This catalog covers:

FH541V- □ S06

GRID NO.

B-10

This grid covers:

CARBURETOR

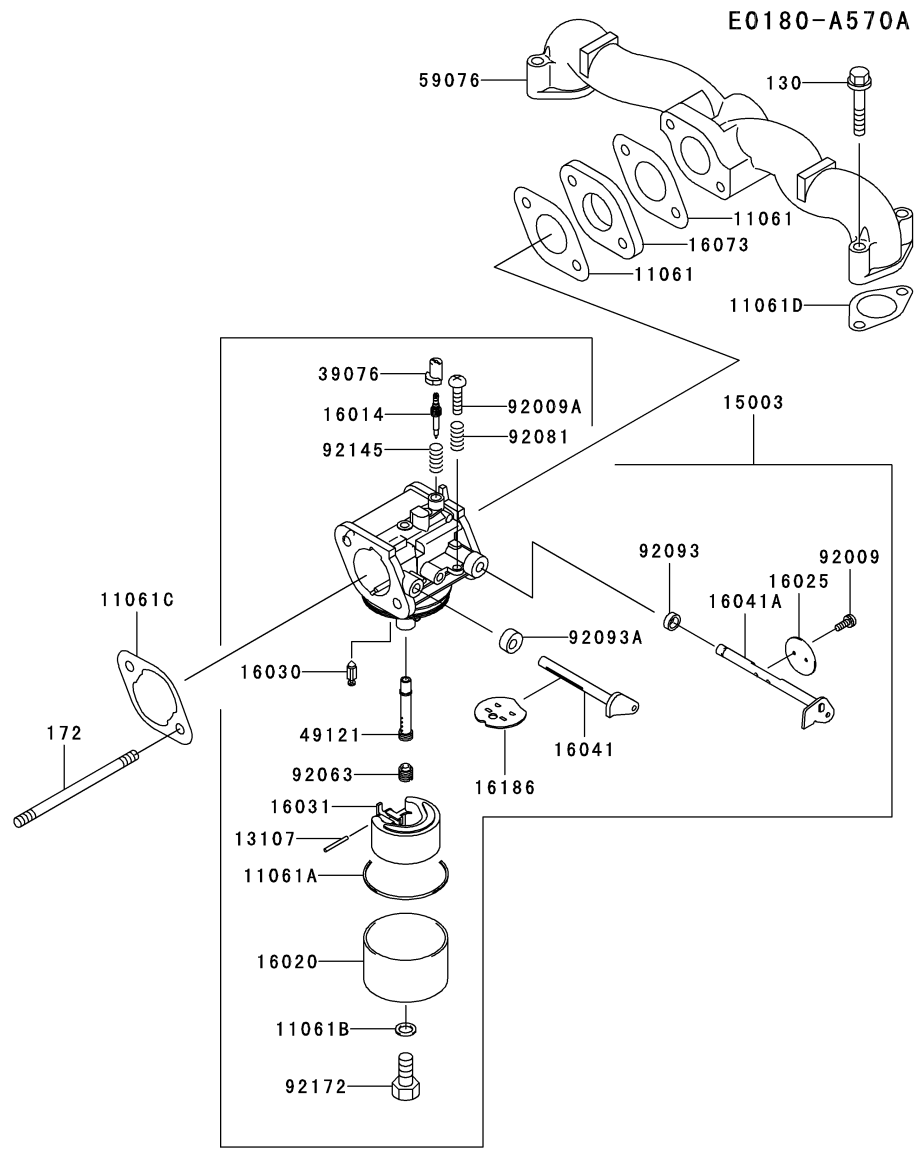

Ref. No.	Part No.	Description	Quantity
			A
11061	11061-7004	GASKET,INSULATOR	2
11061A	11061-7009	GASKET,CHAMBER	1
11061B	11061-7010	GASKET	1
11061C	11061-7018	GASKET,AIR CLEANER	1
11061D	11061-7019	GASKET	2
13107	13107-7018	SHAFT	1
15003	15003-7085	CARBURETOR-ASSY	1
16014	16014-7007	SCREW-PILOT AIR	1
16020	16020-7003	CHAMBER-FLOAT	1
16025	16025-7006	VALVE-THROTTLE	1
16030	16030-7003	VALVE-FLOAT	1
16031	16031-7002	FLOAT	1
16041	16041-7016	SHAFT-CARBURETOR,CHOKE	1
16041A	16041-7018	SHAFT-CARBURETOR,THROTTLE	1
16073	16073-7007	INSULATOR	1
16186	16186-7004	VALVE-ASSY-CHOKE	1
39076	39076-7001	LIMITER	1
49121	49121-7007	NOZZLE-MAIN	1
59076	59076-7001	MANIFOLD-INTAKE	1
92009	92009-2083	SCREW	2
92009A	92009-2349	SCREW	1
92063	92063-7046	JET-MAIN,#100	1
92081	92081-2234	SPRING	1
92093	92093-2100	SEAL	1
92093A	92093-7003	SEAL	1
92145	92145-7015	SPRING	1
92172	92172-7002	SCREW	1
130	130B0635	BOLT-FLANGED	4
172	172G0685	BOLT-STUD	2

This catalog covers:

FH541V- □ S06

GRID NO.

B-11

This grid covers:

AIR-FILTER/MUFFLER

E0190-A700A

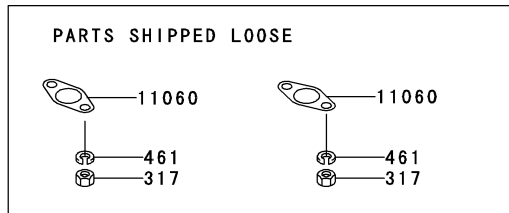
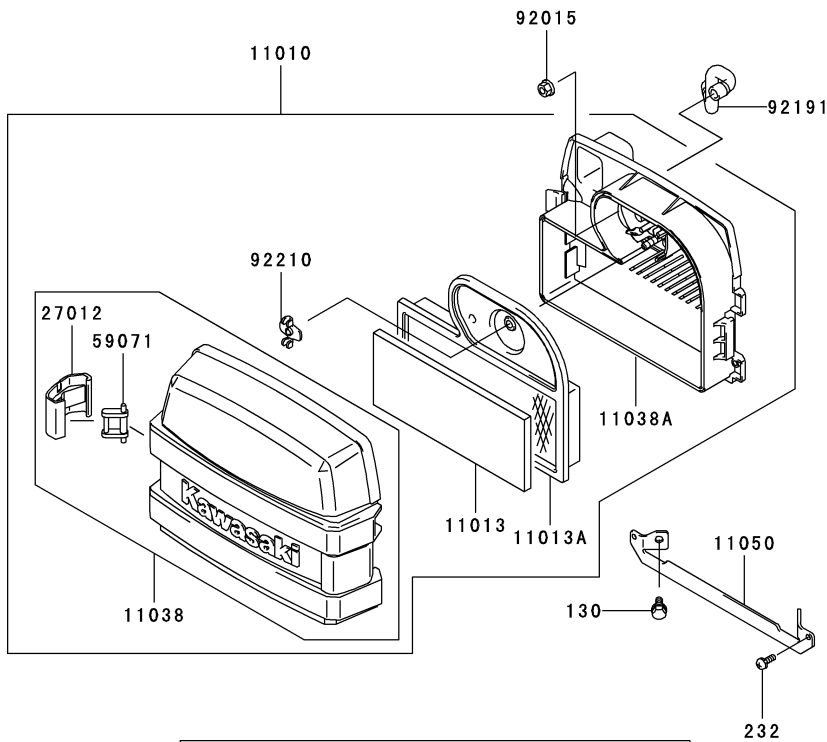

Ref. No.	Part No.	Description	Quantity
11010	11010-7008	FILTER-ASSY-AIR	1
11013	11013-7001	ELEMENT-AIR FILTER	1
11013A	11013-7006	ELEMENT-AIR FILTER	1
11038	11038-7001	CASE-ASSY-AIR FILTER	1
11038A	11038-7006	CASE-ASSY-AIR FILTER	1
11050	11050-7006	BRACKET	1
11060	11060-7021	GASKET,MUFFLER	2
27012	27012-7001	HOOK,AIR FILTER	2
59071	59071-7001	JOINT	2
92015	92015-1193	NUT	2
92191	92191-7001	TUBE	1
92210	92210-7004	NUT	1
130	130B0612	BOLT-FLANGED	2
232	232B0514	SCREW-PAN-WS+	2
317	317R0800	NUT-HEX-SMALL	4
461	461F0800	WASHER-SPRING	4

This catalog covers:

FH541V- □ S06

GRID NO.

C-03

This grid covers:

FUEL-TANK/FUEL-VALVE

E0200-A274A

Ref. No.	Part No.	Description	Quantity
11051	11051-7001	BRACKET	1
92015	92015-1143	NUT	1
92066	92066-2096	PLUG	1
92170	92170-2088	CLAMP	1
92170A	92170-7003	CLAMP	1
92191	92191-7004	TUBE	1
130	130B0620	BOLT-FLANGED	1

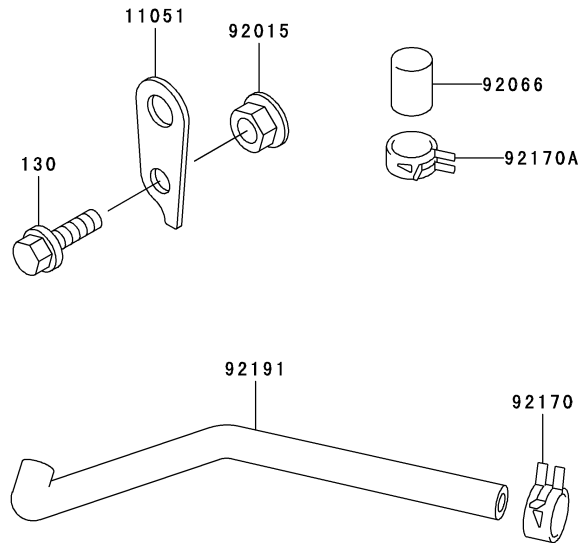

This catalog covers:

FH541V- □ S06

GRID NO.

C-04

This grid covers:

STARTER

E0210-A205A

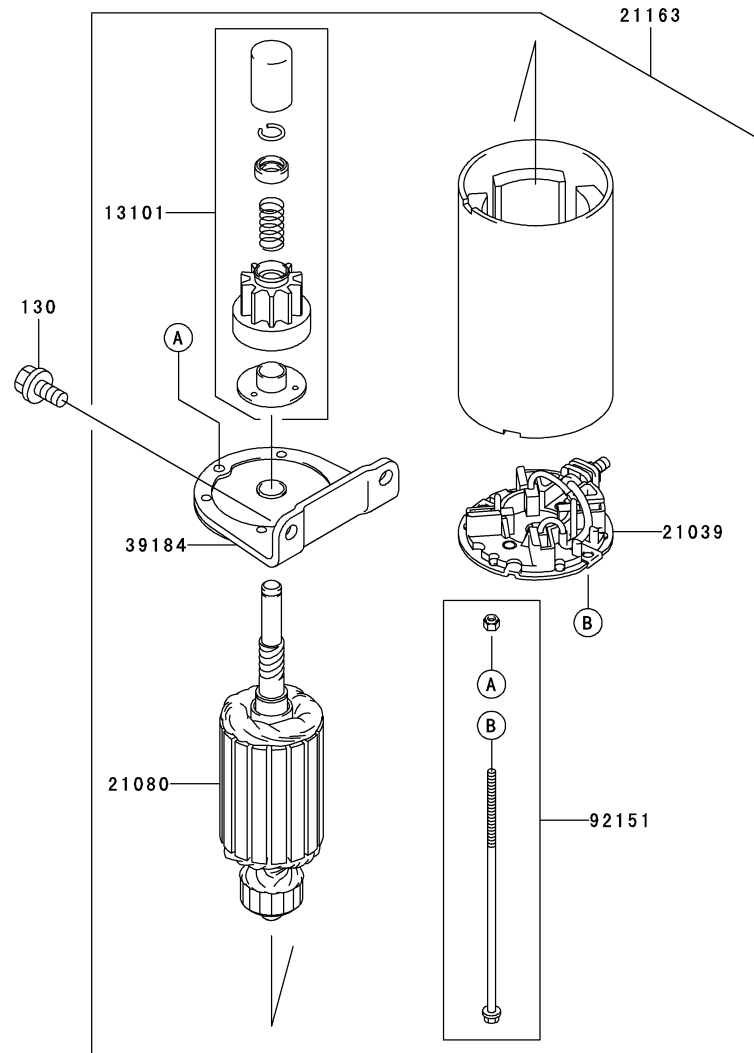

Ref. No.	Part No.	Description	Quantity
			A
13101	13101-7003	GEAR-ASSY	1
21039	21039-7004	BRUSH	1
21080	21080-7001	ARMATURE	1
21163	21163-7010	STARTER-ELECTRIC	1
39184	39184-7004	BRACKET-ASSY	1
92151	92151-7013	BOLT	1
130	130B0816	BOLT-FLANGED	2

This catalog covers:
FH541V- □ S06

GRID NO. This grid covers:
D-03 LABEL

F0290-B053A

Ref. No.	Part No.	Description	Quantity
56033	56033-7002	LABEL-MANUAL	1
56070	56070-7001	LABEL-WARNING	1
56080	56080-7021	LABEL-BRAND	1

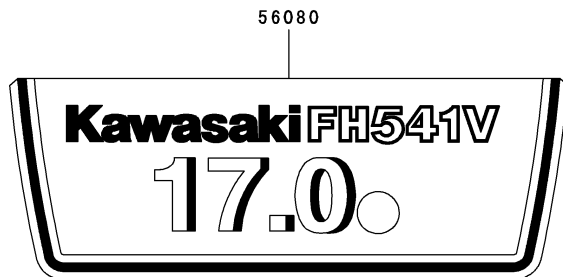
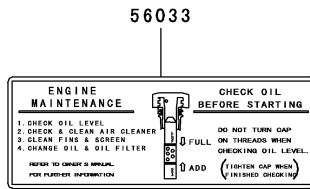

This catalog covers:

FH541V- □ S06

GRID NO.

H-09

This grid covers:

PART NAME INDEX

AIR-FILTER/MUFFLER.....	B-11
CARBURETOR.....	B-10
CONTROL-EQUIPMENT.....	B-09
COOLING-EQUIPMENT.....	B-07
CYLINDER/CRANKCASE.....	B-03
ELECTRIC-EQUIPMENT.....	B-08
FUEL-TANK/FUEL-VALVE.....	C-03
LABEL.....	D-03
LUBRICATION-EQUIPMENT.....	B-06
PISTON/CRANKSHAFT.....	B-04
STARTER.....	C-04
VALVE/CAMSHAFT.....	B-05

This catalog covers:

FH541V- □ S06

GRID NO.

H-10

This grid covers:

NUMERICAL PARTS INDEX

Part No.	Grid No.	Part No.	Grid No.	Part No.	Grid No.	Part No.	Grid No.	Part No.	Grid No.
11004-7010.....	B-03	14091-7006.....	B-03	59066-7002.....	B-07	92210-7004.....	B-11		
11008-6042.....	B-03	15003-7085.....	B-10	59071-7001.....	B-11				
11008-7009.....	B-03	16014-7007.....	B-10	59071-7004.....	B-06				
11010-7008.....	B-11	16020-7003.....	B-10	59076-7001.....	B-10				
11013-7001.....	B-11	16025-7006.....	B-10	59231-7005.....	B-06				
11013-7006.....	B-11	16030-7003.....	B-10	670D2016.....	B-06				
11022-7003.....	B-03	16031-7002.....	B-10	92004-7006.....	B-07				
11038-7001.....	B-11	16041-7016.....	B-10	92004-7009.....	B-08				
11038-7006.....	B-11	16041-7018.....	B-10	92009-2083.....	B-10				
11050-7006.....	B-11	16073-7007.....	B-10	92009-2308.....	B-08				
11051-7001.....	C-03	16154-2053.....	B-06	92009-2341.....	B-05				
11060-7001.....	B-03	16154-2054.....	B-06	92009-2349.....	B-10				
11060-7008.....	B-03	16169-7010.....	B-09	92009-7007.....	B-09				
11060-7021.....	B-11	16171-7001.....	B-09	92015-1143.....	C-03				
11061-7001.....	B-03	16186-7004.....	B-10	92015-1193.....	B-11				
11061-7004.....	B-10	172G0685.....	B-10	92015-2253.....	B-05				
11061-7009.....	B-10	172G0818.....	B-03	92033-7001.....	B-05				
11061-7010.....	B-10	21039-7004.....	C-04	92033-7003.....	B-03				
11061-7018.....	B-10	21066-7011.....	B-08	92033-7005.....	B-04				
11061-7019.....	B-10	21080-7001.....	C-04	92043-7001.....	B-03				
12004-7003.....	B-05	21163-7010.....	C-04	92043-7003.....	B-06				
12005-7003.....	B-05	21171-7013.....	B-08	92049-7001.....	B-03				
12009-7001.....	B-05	21193-7007.....	B-08	92049-7005.....	B-03				
12011-2056.....	B-05	214B0408.....	B-09	92049-7010.....	B-03				
12016-7001.....	B-05	224B0520.....	B-08	92049-7011.....	B-03				
12032-7001.....	B-05	232B0514.....	B-11	92063-7046.....	B-10				
13001-7010.....	B-04	26030-7001.....	B-08	92066-2096.....	C-03				
13002-7001.....	B-04	27010-7002.....	B-08	92066-7002.....	B-03				
13008-6060.....	B-04	27012-7001.....	B-11	92066-7003.....	B-06				
13031-7036.....	B-04	311B0600.....	B-07	92066-7006.....	B-06				
13070-7001.....	B-05	311B0600.....	B-08	92070-7003.....	B-08				
13070-7004.....	B-05	311B0600.....	B-09	92072-7003.....	B-08				
130B0612.....	B-03	317R0800.....	B-11	92081-2234.....	B-10				
130B0612.....	B-06	39076-7001.....	B-10	92093-2100.....	B-10				
130B0612.....	B-07	39129-7003.....	B-09	92093-7003.....	B-10				
130B0612.....	B-09	39184-7004.....	C-04	92140-7002.....	B-05				
130B0612.....	B-11	411B0600.....	B-09	92140-7003.....	B-06				
130B0616.....	B-07	42036-7009.....	B-05	92145-7001.....	B-05				
130B0620.....	B-08	461F0800.....	B-11	92145-7002.....	B-06				
130B0620.....	C-03	49015-6253.....	B-03	92145-7003.....	B-09				
130B0625.....	B-07	49065-2078.....	B-06	92145-7004.....	B-09				
130B0635.....	B-10	49065-7004.....	B-06	92145-7005.....	B-09				
130B0640.....	B-03	49078-7001.....	B-05	92145-7015.....	B-10				
130B0816.....	B-07	49089-7002.....	B-07	92150-2182.....	B-09				
130B0816.....	C-04	49089-7032.....	B-07	92151-2097.....	B-08				
130T0850.....	B-03	49089-7034.....	B-07	92151-7013.....	C-04				
130T0875.....	B-03	49103-7004.....	B-09	92151-7017.....	B-04				
13101-7003.....	C-04	49109-7002.....	B-03	92153-7005.....	B-09				
13107-7009.....	B-06	49113-7011.....	B-09	92153-7007.....	B-07				
13107-7010.....	B-09	49118-7004.....	B-05	92153-7008.....	B-07				
13107-7018.....	B-10	49120-7023.....	B-03	92153-7019.....	B-05				
13116-2057.....	B-05	49121-7007.....	B-10	92170-2088.....	C-03				
13251-7010.....	B-04	510A5100.....	B-08	92170-7001.....	B-09				
13270-7007.....	B-07	55020-7004.....	B-07	92170-7003.....	C-03				
13271-7007.....	B-05	56033-7002.....	D-03	92172-7002.....	B-10				
13271-7016.....	B-03	56070-7001.....	D-03	92191-7001.....	B-11				
13271-7017.....	B-06	56080-7021.....	D-03	92191-7004.....	C-03				
13271-7018.....	B-09	59031-7001.....	B-08	92200-7001.....	B-05				
13271-7021.....	B-05	59041-7010.....	B-07	92200-7002.....	B-08				
14075-7009.....	B-06	59051-7011.....	B-06	92210-0003.....	B-07				